

PS Communicator 3G

Manual for Installation and Operation



Contents

1	Introduction	2
1.1	Product description	2
1.2	Product features	2
2	Storage and Handling	3
3	Ambient and operating conditions	3
4	Installation	4
4.1	Power supply	4
4.2	Wiring	4
4.2.1	Battery	4
4.2.2	PV-Module	4
4.2.3	Fuse	4
4.3	Assembly of PV-Module bracket	5
4.4	Placement of the PS Communicator	5
5	Start-up and operation	6
6	Trouble shooting	7
6.1	Missing pump connection	7
6.2	No connection to telecommunication network	7
6.3	No connection to LORENTZ server	7
6.4	Low Voltage Disconnect	7
6.5	Overheat Safety Shutdown	7
6.6	SIM card	7

1 Introduction

Thank you for purchasing a LORENTZ PS Communicator 3G

Pre-installation checklist

Check the item numbers of all the components of your system, and verify that they are the items that you ordered.

Read this manual in full. Store the manual and the replacement parts near to the PS Communicator 3G. Install any pump systems that the PS Communicator 3G will connect to. The pump controllers must be equipped with the PS DataModule. Please check from the item numbers that the controller has a DataModule pre-installed.

Subscribe to the pumpMANAGER service which includes SIM card activation.

1.1 Product description

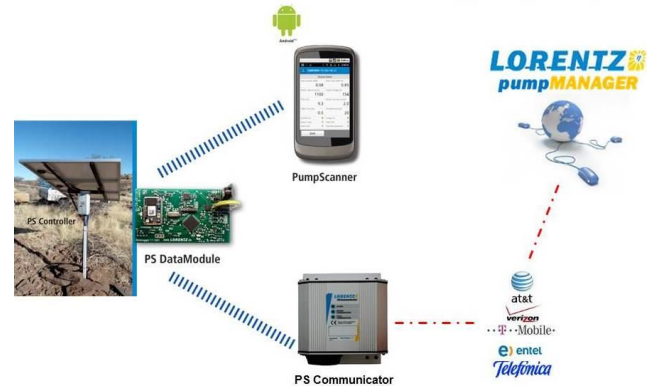

LORENTZ PS DataModule

The LORENTZ PS DataModule is an integral data logger and remote control device for the whole PS and PSk2 range of helical, centrifugal and surface pumps. The PS DataModule is pre-installed in PS Controllers and embedded in PS2 and PSk2 Controllers with Smart Solution support. The PS DataModule measures the key data from the pump system and stores it in on-board memory. Depending on the sample rate up to 10 years of data can be stored.

LORENTZ PumpScanner

To view real-time data or to collect historic data from the PS DataModule an application called "PumpScanner" is used. PumpScanner runs on the Android Operating System (smartphone or tablet) and communicates with the PS DataModule via Bluetooth. The communication distance is up to 10 m (33 ft). Pump setting changes such as on/off timers and speed control can also be made.

LORENTZ PS Communicator 3G

The communicator is used to control and read the values and stored data of a pump system (equipped with a LORENTZ DataModule) via remote control comfortably from home, office or on the road. It is possible to handle several pump systems.

LORENTZ pumpMANAGER.

This is a web based service for monitoring and controlling LORENTZ solar pump systems. The pump Manager provides:

- recording of voltages, current, flow rates, pump speed of monitored pumps
- real time and historical data views
- remote configuration and programming of pump systems
- proactive alerts via email and SMS in the event of a system problem

With a LORENTZ solar pump system and pumpMANAGER you can talk to your pump from anywhere.

1.2 Product features

The LORENTZ PS Communicator 3G has the following features:

- Connection to a maximum of 8 pump systems within Bluetooth range
- Grid-independent 24h power supply
- Long life expectancy and proven in service record
- Designed for use in remote and harsh conditions
- Self monitoring of battery voltage, signal strength, temperature and irradiation
- Smart modular design for simple and cost effective servicing and repair
- Fast and simple installation
- Engineered in Germany

2 Storage and Handling

On receipt of your product check that the packaging is undamaged and complete. If any abnormality is found, contact your distributor. The LORENTZ PS Communicator 3G is supplied from the factory in proper packing. It should remain in the packaging until it is to be installed. Handle the PS Communicator 3G with care and avoid unnecessary impacts and shocks. **The required battery and PV module must be ordered separately.**

Prolonged intermediate storage in an environment of high humidity and fluctuating temperatures must be avoided. Moisture condensation may damage electrical and metal parts. Non-compliance will void any warranty. It is recommended to store the parts in a closed and dry room. The PS Communicator 3G can be stored in the range of -4 °F to 122 °F (-20 °C to 50 °C). The PS Communicator should not be exposed to direct sunlight.

3 Ambient and operating conditions

Operating temperature - The PS Communicator 3G should only be operated in a temperature range of 5°F to 122°F (-15°C to +50°C).

Humidity and air salinity - The PS Communicator 3G must not be operated where the day average humidity is above 80% or in saline air with more than 2µg/m³.

Altitude - The PS Communicator 3G must not be installed at altitudes above + 3000m m.s.l. (other altitudes on request)

4 Installation

The installation should be done with great care and diligence. Before starting, remove the bottom lid (with cable glands and 2G / 3G antenna) and pull out the baseplate carefully. Close the bottom lid, when all work has been done. It is not necessary to open the upper lid of the PS Communicator 3G.

WARNING: Never connect any other power source to the "SOLAR IN" terminal than the PV module that is specified below. The PS Communicator will periodically short-circuit the input to measure the irradiation. Any other power source would consequently damage the device and/or the power source itself.

Note: If an external power supply must be used, do not connect the PV module. Connect a 12V DC power supply to the battery input instead of the battery. Irradiation measurement will not be possible in this configuration.

4.1 Power supply

The PS Communicator 3G gains its grid independent power from a battery charged by a PV-module. **The required battery and PV module must be ordered separately.**

Battery

If a battery is **not** delivered by Lorentz. It must meet the following characteristics:

- Genesis NP7-12 or similar. Sealed 12V AGM lead acid battery
- Min. capacity: 5Ah
- Max. dimensions without connector: 151 x 70 x 95 mm (5.94 x 2.56 x 3.74 in)
- height overall max. 100mm (3.94 in)
- Connector: 4.8 mm (0.189 in) faston tabs

It is possible to purchase a battery from LORENTZ. Contact your distributor for further information.

PS Communicators delivered by LORENTZ, with batteries included, must be re-charged every 6 months during storage.

PV-module

The PV-module has the following features:

- LORENTZ LC20-12M PV panel or similar DC power supply
- Input voltage: 15...18 V DC
- Rated power: 0.5...1.5 W
- Peak current draw: 1.5 A DC
- Pre-wired solar cable with 1mm² phases

The PV-Module is not only for battery charging. It is also used as a measurement sensor for irradiation detection. If a PV-module other than the LORENTZ LC20-12M is used, it must meet the following characteristics:

Table 1: Necessary PV-Module characteristics

characteristic	P _{max}	I _{mp}	V _{mp}	I _{sc}	V _{oc}
unit	[Wp]	[A]	[V]	[A]	[V]
value	20	1.2	17.2	1.3	21.6

4.2 Wiring

The wiring must be done by qualified staff only. The kit includes two green plugs, one is for the battery and already pre assembled with a red (plus) and black (minus) cable. The second plug is for Solar In. The two plugs must be removed from the board before wiring. The socket on the left lower edge of the board is for the PV-Module cables (labeled with "SOLAR IN"). The socket on the right lower side of the board is for the battery cables (labeled with "BATTERY").

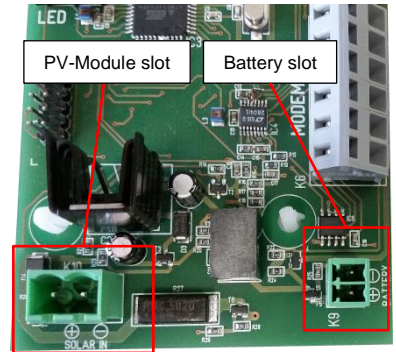

Figure 1: PS Communicator 3G wiring slots

4.2.1 Battery

Use the 2 pin battery plug with the pre-assembled cables. The red cable is for plus (+), the black cable is for minus (-).

Make sure the cables are securely mounted to the battery. Ensure and check the correct polarity.

Remove the battery fixing screw. Slide in the battery. Ensure the battery is correctly seated and secure it with the battery fixing screw.

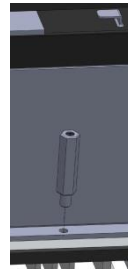

Figure 2: Battery fixing

4.2.2 PV-Module

The PV-module has a pre-wired cable. The numbering of the phases is printed on the cable jacket of the phases (1 is for plus (+), 2 is for minus (-)). Thread the cable through the left cable-gland in the bottom lid. Use the rubber seal (from the plug in the cable-gland) to seal the cable entry. Connect the cable to the Solar in Terminal. The left terminal is for plus, the terminal to the right is for minus. Use the cable-gland in the bottom lid for strain relieve and sealing.

Do not connect the plug at this point. The PS Communicator 3G start-up is described in chapter 5.

4.2.3 Fuse

The fuse will blow in the event of a battery voltage reversal. The fuse is switched in the red cable (plus) of the battery cable. Pull out and replace the fuse if it is broken. The fuse has no special orientation.

- 2A fast-acting ATO fuse



One fuse is pre-installed to the Battery cable, another two fuses are delivered as replacements.

4.3 Assembly of PV-Module bracket

We recommend that you use the delivered PV-Module bracket and to install it as mentioned in this section.

Assemble the brackets to the pre-assembled PV-module braces. Use four M6x16 screws (with 1x washer and 1x spring washer) as shown in **Error! Reference source not found.** Fasten the screws with 10Nm.

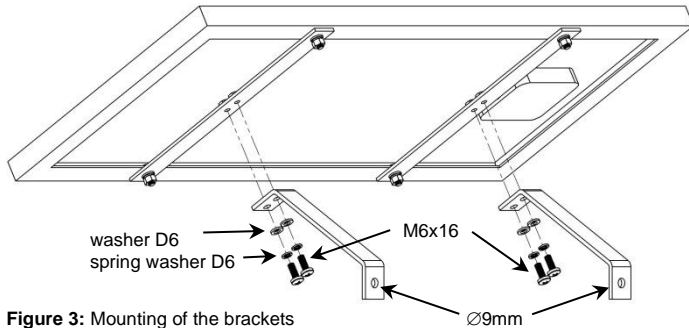

Figure 3: Mounting of the brackets

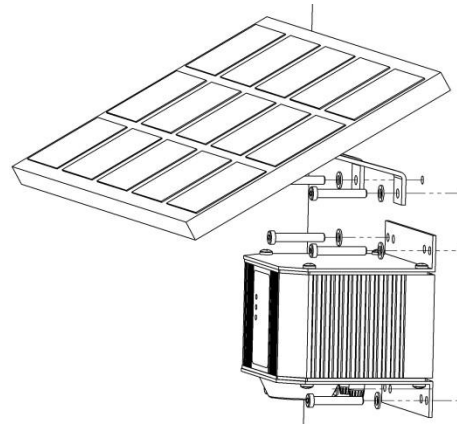

Figure 5: Mounting PS Communicator 3G and its PV-Module to a wall

4.4 Placement of the PS Communicator 3G

The Communicator must be placed near to the pump controller. The maximum Bluetooth range is up to 10m but depends on the surrounding conditions. For example; walls, shelters or other signals may weaken the signal strength. Keep the PV-Module free of shadow and with a South (Northern Hemisphere) or North (Southern Hemisphere) orientation. The PV-Module must be kept clean from dirt and snow.

It is recommended to complete the wiring, SIM card installation, battery installation and an established pump connection before finally mounting the PS Communicator 3G to a wall. See the Start-up section on next page.

To mount the PS Communicator 3G to a wall look at the hole-template below (Figure 4). You just need four of the eight shown holes (for the PS Communicator 3G); EITHER the four outer holes OR the four inner holes.

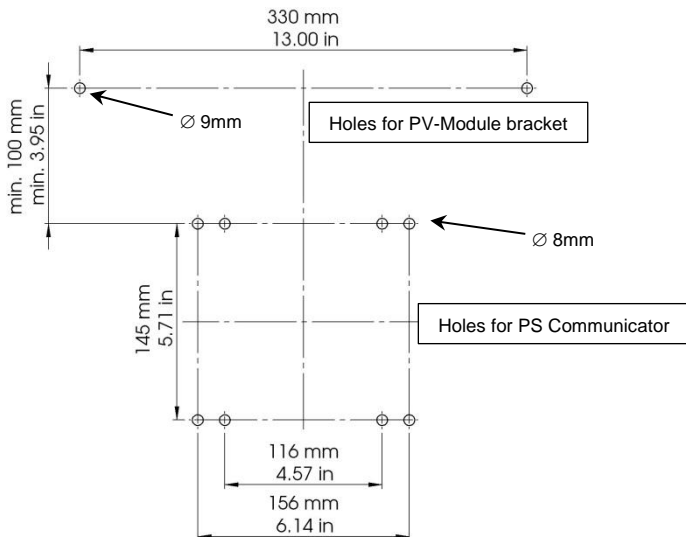

Figure 4: Bore template for wall mounting

Fix the PS Communicator 3G with screws on top (see Figure 5). Two more screws can be used if needed. In that case use the holes in the bottom lid of the communicator.

Place the PV-Module holder at least 10cm (3.95 in) above the PS Communicator 3G. The holes in the wall, for the PV-Module holder, have to be 330mm (13.0 in) away from each other. Use M8 screws.

5 Start-up and operation

This chapter describes the start-up of the PS Communicator.

1. Verify that all pump controllers are installed and have PS DataModules installed.
2. Ensure that every DataModule has been connected to and configured by the PumpScanner, before the PS Communicator 3G links to them.
Note : If you cannot configure the pump system via PumpScanner (no pairing PIN) the system can be configured via pumpMANAGER after connection.
3. Make sure that the pumpMANAGER service subscription (which includes SIM card activation) has been done on partnerNET.
4. Ensure all pumps within Bluetooth range have power connected to them. If you are using PumpScanner on any Android device, disconnect it from the pump before powering the communicator.
5. Connect the power plugs (green plugs inside the PS Communicator 3G).
6. The device will start-up by itself. It starts initialization and searching for pumps in range (via bluetooth). It then subsequently tries connecting to a telecommunication network (via 2G/3G) and the LORENTZ pumpMANAGER server. To restart the device and reset the pump pairing , simply disconnect the power plug for one second and reconnect it.
7. The normal PS communicator 3G LED status is:
 - SYSTEM LED is flashing green every 5 seconds
 - DISTANT COMMUNICATION LED is flashing yellow every 5 seconds
 - LOCAL COMMUNICATION LED is flashing X times (see Table 2 and example below) every 5 seconds blue

They all start flashing at the same time.

8. When the PS Communicator 3G is connected to the LORENTZ server and all pumps are connected, slide in the baseplate and close the bottom lid. Take care to not jam any cables between the housing and the bottom lid. Ensure the cable glands are tight.
9. If you have not already done so mount the PS communicator 3G to the wall.

The PS Communicator 3G has an LED bar with 3 LEDs to display the status:

- | | |
|--------------------------|--------------|
| 1. SYSTEM | green or red |
| 2. DISTANT COMMUNICATION | yellow |
| 3. LOCAL COMMUNICATION | blue |

The table below describes the light sequence of the PS Communicator 3G LED bar. If any abnormality occurs check the LED status below, especially the "SYSTEM"-LED (red).

Table 2: LED sequence

LED	Sequence	Description
SYSTEM (green)	500 ms on, 500 ms off	Hardware initialization
	every 5 sec flashing	System active
	off	System not active
SYSTEM (red)	50 ms on, 450 ms off	Device not initiated, contact LORENTZ Partner
	every 5 sec flashing	Low voltage disconnect
	every 5 sec flashing twice	Overheat safety shutdown
DISTANT COMMUNICATION (yellow)	500 ms on, 500 ms off	Connecting to telecommunication network
	50 ms on, 450 ms off	Connecting to LORENTZ server
	every 5 sec flashing	Connected to LORENTZ server
	off	No telecommunicationnetwork found or connected
LOCAL COMMUNICATION (blue)	500 ms on, 500 ms off	Searching for pumps
	50 ms on, 450 ms off	Connecting to a pump
	every 5 sec flashing X times	X = Number of paired devices *
	off	No active communication, no pump found

*) Example:

❖ X=1

➤ Connected to 1 pump

❖ X=3

➤ Connected to 3 pumps

6 Trouble shooting

6.1 Missing pump connection

If a pump controller does not connect to the PS Communicator 3G check that:

- The pump system has a DataModule installed. PS Controllers that are equipped with a DataModule have 2 serial numbers on the casing, one for the Controller and one for the DataModule
- A green system light is shown on the pump controller
- there is **no** active PumpScanner connection to the pump system
- there are not more than 8 PS Controllers within range of the PS Communicator 3G. In this situation the 9th pump would not connect.
- the BlueTooth signal strength is not being impaired by obstacles, walls or other interfering signals or mounting the PS Communicator 3G in a metal box.

6.2 No connection to telecommunication network

If the PS Communicator 3G does not connect to the telecommunication (2G/3G) network check that:

- the SIM card is well seated
- You are using the SIM card supplied by LORENTZ, the PS Communicator 3G will not work with any other SIM cards
- the antenna cable is screwed tightly to the 2G/3G terminal
- there is a mobile phone signal at the site
NOTE: You could use your smartphone to roughly ascertain the signal strength at the installation site.
- - if the circumstances require, test the PS Communicator 3G In an area with a known good signal (within 1km of a radio mast)
- the PS Communicator 3G is not installed in a location where the signal will be impaired. Signal strength will be reduced by walls, metal objects, obstacles, being too distant from each other, interfering signal, etc.)
 - if the circumstances require, test the PS Communicator 3G in an open area directed to the radio mast
- the antenna cable is not broken

The PS communicator 3G will try to find a network until it is connected. If it does not find a network there is the risk of emptying the battery.

6.3 No connection to LORENTZ server

If the PS Communicator 3G is not able to establish a connection to the LORENTZ server contact your distributor for further information.

6.4 Low Voltage Disconnect

The Low Voltage Disconnect (LVD) activates if the battery's voltage drops below 11.8 volts. The LVD is a protective feature to safe the battery from deep discharge. The SYSTEM LED flashes red. During LVD there is no Bluetooth or 2G / 3G connection possible.

The PS Communicator 3G returns to normal mode after the battery recovers to 12.2 volts. The voltage is checked once per minute.

6.5 Overheat Safety Shutdown

The Overheat Safety Shutdown is to protect the electronic devices from overheating. It activates if the temperature in the PS Communicator 3G exceeds 95°C (203°F). The SYSTEM LED flashes red. During the overheat shutdown there is no Bluetooth or 2G/3G connection possible.

The PS Communicator 3G returns to normal mode when the temperature has fallen below 90°C (194°F). The temperature is checked once per minute.

6.6 SIM card

To insert the SIM card into the 2G/3G terminal make sure that the SIM card's contacts are facing left and that the cut-off corner is pointing upwards as the illustration (Figure 6) shows.

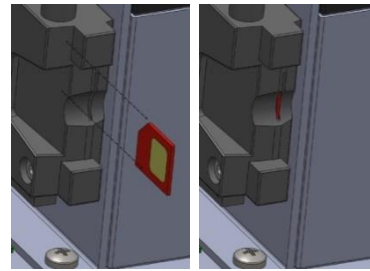

Figure 6: Insert SIM card

The SIM card must "click" in and should be flush with the outer case (of the 2G / 3G Terminal). Use a pen or small screw driver to gently push it in (not much pressure needed).

To remove the SIM card push the card in slightly to release the lock and the card will be pop out automatically. You can remove now the SIM card. Do not pull the card while it is locked in the 2G / 3G terminal.